

Atlas Copco Rock Drilling Tools

SECOROC Down the hole equipment

Hydrocyclone™ and Jet Sub



Dry Hole. Better Performance.

Fluids need to be injected to clean a drilled hole, and until Hydrocyclone™ technology, drilling speeds were compromised as fluids were injected. Atlas Copco's exclusive, patented system expels injected fluids just above the down-hole drill. The result? As much fluid as necessary can be injected without concern for loss of performance. The hole stays clean, and the hammer runs as if it were operating dry.

Over-the-hammer Jet Subs allow large volumes of air to be bypassed above the hammer. This feature reduces operating pressure and allows more hole cleaning for deep, wet or soft rock applications.

Atlas Copco

Hydrocyclone™ & Jet Sub Specifications

Hydrocyclone™ Kits

Size	Part number	Description	Thread	Outside diameter English	Length (shoulder to shoulder)	Wrench flat size	Max orifice size (six holes)	Weight
3 1/2"	52333853	Assembly with 1/8" orifice (6 GPM at 350 psig)	3 1/2" API reg pin X box, pin up	5.60" / 142 mm	14.6" / 371 mm	4 AF X 2 1/4"	2 X 1/8"	68 lb / 31 kg
4 1/2"	52340056	Assembly with blank plate (14 GPM at 350 psig)	4 1/2" API reg pin X box, pin up	7.13" / 181 mm	22.5" / 181 mm	5.9 AF X 2 1/4"	2 X 3/16"	156 lb / 71 kg

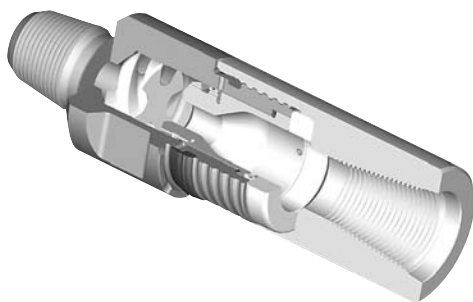

Hydrocyclone™ Features & Benefits

- Increases performance with liquid injection
- Expels liquids above DHD
- Excellent choice for Oil & Gas and Waterwell applications

Hydrocyclone™ Platforms

Complete hammer availability

Size	DHD	QL	TD	COP
3				
4				
5		QL50HC		
6		QL60HC	3 1/2" KIT	3 1/2" KIT
8	DHD380HC	QL80HC	4 1/2" KIT	
10				
12	DH12HC	QL120HC		

Jet Sub Adapters

Size	Part number	Description	Thread	Outside Diameter	Length (shoulder to shoulder)	Wrench flat size	Max orifice size (six holes)	Weight
2 3/8"	52340312 with blank plate	2 3/8" API assembly X box, pin up	2 3/8" API reg pin	3.69" / 94 mm	6.1" / 155 mm	2 1/2" AF X 1 3/4"	0.13" / 3.3 mm	15 lb/7 kg
3 1/2"	52340213 with blank plate	3 1/2" API assembly X box, pin up	3 1/2" API reg pin	5.44" / 138 mm	6.38" / 162 mm	4" AF X 1 3/4"	0.19" / 4.8 mm	35 lb/16 kg

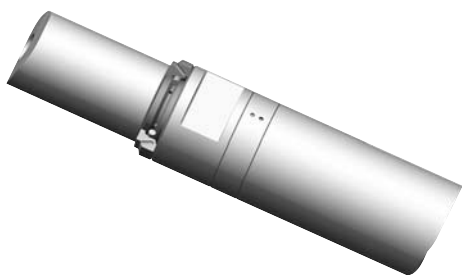

Jet Sub Features & Benefits

- Increases down-the-hole air capacity without need for booster
- Improves cuttings removal in deep holes
- Increased down-the-hole performance

Jet Sub Platforms

Complete hammer availability

Size	DHD	QL	TD	COP
3				
4		2 3/8" KIT	2 3/8" KIT	2 3/8" KIT
5				
6	3 1/2" KIT	3 1/2" KIT	TD60	3 1/2" KIT
8			TD80	
10				
12				
20				

Atlas Copco

Atlas Copco Secoroc AB

Box 521, SE-737 25 Fagersta, Sweden
Tel +46 223 461 00 – Fax +46 223 461 01

www.atlascopco.com