

# Atlas Copco Rock Drilling Tools

## SECOROC Down the hole equipment

### Cluster Drills



#### **Multiple down-hole drills — Single Canister**

Atlas Copco offers a hard rock drilling system capable of drilling thirty-two to seventy inch diameter holes by combining multiple down-hole drills into a single canister. These drills are custom engineered and manufactured to meet each customer's unique hole size requirements. The drills are short, light weight and compact, featuring exclusive, patented technology for self-indexing and quick-release bits. The bottom line: Servicing is infrequent and unusually efficient.

# Cluster Drill Specifications

## Features & Benefits

- Short, lightweight package which will easily adapt to many Geo-Technical drill platforms.
- Highly efficient and reliable CS8 hammers provide power with minimal air consumption.
- Modular build allows rapid construction of custom diameter units.
- Quick-Change bits can be removed and serviced without costly and time consuming disassembly of the drill.
- Dual-manifold can and module construction allows use in reverse circulation mud-water flushed applications.

Model	Diameter		Number of Hammers		Length		Weight		Air Consumption (psig/bar)		
	inch	mm	Gage	Face	inch	mm	lb	kg	psig/bar	scfm	l/s
CDS36 5/4	36	915	4	1	63	1600	6,3	2,8	100/6.9	1480	700
									125/8.6	2006	947
									150/10.3	2595	1225
									175/12.1	3246	1532
CDS42 7/4	42	1067	4	3	63	1600	8,8	4	200/13.8	3960	1869
									100/6.9	2072	978
									125/8.6	2809	1326
									150/10.3	3633	1715
CDS46 7/4	46	1169	4	3	63	1600	9,5	4,3	175/12.1	4544	2145
									200/13.8	5543	2616
									100/6.9	2072	978
									125/8.6	2809	1326
CDS48 7/4	48	1219	4	3	63	1600	10	4,5	150/10.3	3633	1715
									175/12.1	4544	2145
									200/13.8	5543	2616
									100/6.9	2072	978
CDS54 9/5	54	1372	5	4	63	1600	12,7	5,8	125/8.6	2809	1326
									150/10.3	3633	1715
									175/12.1	4544	2145
									200/13.8	5543	2616
CDS60 11/5	60	1524	5	6	63	1600	15,7	7,1	100/6.9	2664	1257
									125/8.6	3611	1704
									150/10.3	4671	2205
									175/12.1	5843	2758
CDS70 13/5	70	1778	5	8	63	1600	20	9,1	200/13.8	7127	3364
									100/6.9	3256	1537
									125/8.6	4414	2083
									150/10.3	5709	2694
									175/12.1	7141	3370
									200/13.8	8711	4111
									100/6.9	3848	1816
									125/8.6	5216	2462
									150/10.3	6747	3184
									175/12.1	8440	3983
									200/13.8	10295	4859

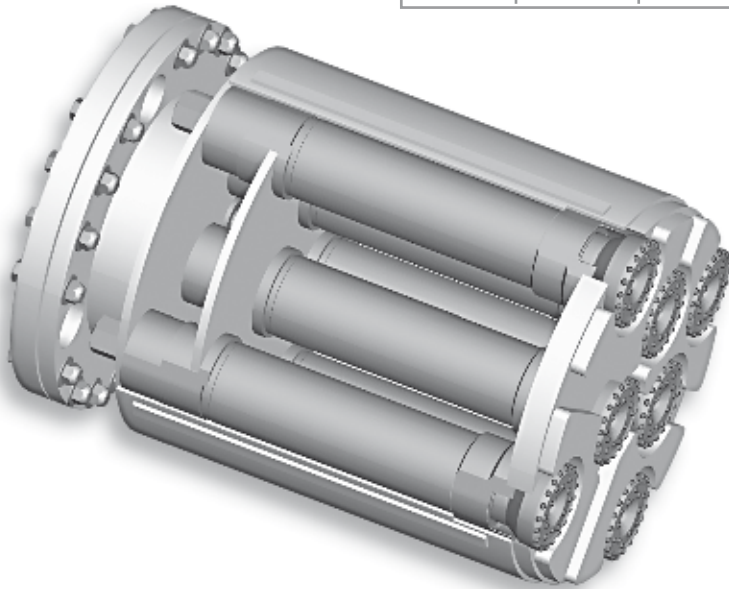

**Atlas Copco Secoroc AB**  
 Box 521, SE-737 25 Fagersta, Sweden  
 Tel +46 223 461 00 – Fax +46 223 461 01  
[www.atlascopco.com](http://www.atlascopco.com)